

The logo for EGASEN features the company name in a bold, italicized, white sans-serif font. The text is contained within a dark grey oval shape that is partially enclosed by a bright orange swoosh on the right side.

***EGASEN***

# TARIFA MOTORES Y REDUCTORES

v2.1

[www.egasen.com](http://www.egasen.com)





Motores Monofásicos



Motores Trifásicos



Motores con Freno



Pre-Reducción



Reductores Sinfín Corona



Reductores para sistemas de alimentación de ganadería (Avícola, Porcino, ...)



Reductores Ortogonales



Reductores Coaxiales de Engranajes



Reductores Ortogonales Hipoides



Reductores Pendulares

**DUCATI** energia



Baterías automáticas



Baterías autorregulables



Reguladores



Condensadores



Armarios IP66



Armarios en acero inoxidable



Armarios en poliéster



Cajas de doble aislamiento

**MOTORES TRIFÁSICOS IE2 (ALTA EFICIENCIA)**
**IE2**

Serie MT (Aluminio)/MTY (Fundición) Motores Eléctricos Trifásicos, ATX IE2, IP55, AISL.CI.F, servicio S1, 230/400V y 400/690V, 50/60Hz

2 POLOS (3.000 RPM)						4 POLOS (1.500 RPM)					
kW	CV	Tipo	B3	B5/B14	B35/B34	kW	CV	Tipo	B3	B5/B14	B35/B34
0,12	0,2	MT562-2 *				0,06	0,08				
0,18	0,25	MT631-2 *				0,09	0,12	MT562-4 *			
0,25	0,33	MT632-2 *	89 €	92 €	96 €	0,12	0,17	MT631-4 *	78 €	80 €	84 €
0,37	0,5	MT711-2 *	94 €	96 €	101 €	0,18	0,25	MT632-4 *	82 €	84 €	88 €
0,55	0,75	MT712-2 *	104 €	107 €	113 €	0,25	0,33	MT711-4 *	99 €	102 €	107 €
0,75	1	MT801-2	154 €	159 €	167 €	0,37	0,5	MT712-4 *	106 €	109 €	114 €
1,1	1,5	MT802-2	170 €	175 €	184 €	0,55	0,75	MT801-4 *	138 €	142 €	149 €
1,5	2	MT90S-2	207 €	213 €	223 €	0,75	1	MT802-4	169 €	174 €	183 €
2,2	3	MT90L1-2	256 €	264 €	277 €	1,1	1,5	MT90S-4	206 €	212 €	222 €
3	4	MT100L1-2	311 €	320 €	336 €	1,5	2	MT90L-4	238 €	245 €	257 €
4	5,5	MT112M-2	412 €	424 €	445 €	2,2	3	MT100L1-4	298 €	307 €	322 €
5,5	7,5	MT132S1-2	524 €	540 €	566 €	3	4	MT100L2-4	331 €	341 €	358 €
7,5	10	MT132S2-2	607 €	625 €	656 €	4	5,5	MT112M-4	406 €	418 €	439 €
11	15	MTY160M1-2	938 €	966 €	1.013 €	5,5	7,5	MT132S-4	578 €	595 €	624 €
15	20	MTY160M2-2	1.040 €	1.071 €	1.123 €	7,5	10	MT132M-4	681 €	701 €	735 €
18,5	25	MTY160L-2	1.158 €	1.193 €	1.251 €	11	15	MTY160M-4	1.038 €	1.069 €	1.121 €
22	30	MTY180M-2	1.620 €	1.669 €	1.750 €	15	20	MTY160L-4	1.220 €	1.257 €	1.318 €
30	40	MTY200L1-2	2.078 €	2.140 €	2.244 €	18,5	25	MTY180M-4	1.468 €	1.512 €	1.585 €
37	50	MTY200L2-2	2.200 €	2.266 €	2.376 €	22	30	MTY180L-4	1.625 €	1.674 €	1.755 €
45	60	MTY225M-2	2.678 €	2.758 €	2.892 €	30	40	MTY200L-4	2.135 €	2.200 €	2.306 €
55	75	MTY250M-2	3.300 €	3.399 €	3.564 €	37	50	MTY225S-4	2.520 €	2.596 €	2.722 €
75	100	MTY280S-2	4.400 €	4.532 €	4.752 €	45	60	MTY225M-4	2.896 €	2.982 €	3.127 €
90	125	MTY280M-2	4.668 €	4.808 €	5.041 €	55	75	MTY250M-4	3.570 €	3.677 €	3.855 €
110	150	MTY315S-2	*	*	*	75	100	MTY280S-4	4.585 €	4.723 €	4.952 €
132	180	MTY315M-2	*	*	*	90	125	MTY280M-4	5.116 €	5.270 €	5.525 €
160	220	MTY315L1-2	*	*	*	110	150	MTY315S-4	8.488 €	8.743 €	9.167 €
200	270	MTY315L2-2	*	*	*	132	180	MTY315M-4	9.600 €	9.888 €	10.368 €
250	340	MTY355M-2	*	*	*	160	220	MTY315L1-4	10.380 €	10.691 €	11.210 €
315	430	MTY355L-2	*	*	*	200	270	MTY315L2-4	11.400 €	11.742 €	12.312 €
						250	340	MTY355M-4	17.400 €	17.922 €	18.792 €
						315	430	MTY355L-4	19.488 €	20.073 €	21.047 €

6 POLOS (1.000 RPM)											
kW	CV	Tipo	B3	B5/B14	B35/B34	kW	CV	Tipo	B3	B5/B14	B35/B34
0,18	0,25	MT711-6 *				18,5	25	MTY200L1-6	1.795 €	1.848 €	1.938 €
0,25	0,33	MT712-6 *				22	30	MTY200L2-6	1.953 €	2.012 €	2.110 €
0,37	0,5	MT801-6 *				30	40	MTY225M-6	2.687 €	2.767 €	2.902 €
0,55	0,75	MT802-6 *	164 €	169 €	177 €	37	50	MTY250M-6	3.146 €	3.240 €	3.398 €
0,75	1	MT90S-6	224 €	231 €	242 €	45	60	MTY280S-6	3.710 €	3.821 €	4.007 €
1,1	1,5	MT90L-6	251 €	258 €	271 €	55	75	MTY280M-6	4.420 €	4.553 €	4.774 €
1,5	2	MT100L-6	320 €	330 €	346 €	75	100	MTY315S-6	8.379 €	8.631 €	9.050 €
2,2	3	MT112M-6	410 €	422 €	443 €	90	125	MTY315M-6	9.202 €	9.478 €	9.938 €
3	4	MT132S-6	550 €	567 €	594 €	110	150	MTY315L1-6	10.964 €	11.293 €	11.841 €
4	5,5	MT132M1-6	610 €	628 €	659 €	132	180	MTY315L2-6	11.843 €	12.198 €	12.791 €
5,5	7,5	MT132M2-6	680 €	700 €	734 €	160	220	MTY355M1-6	15.997 €	16.477 €	17.277 €
7,5	10	MTY160M-6	897 €	924 €	969 €	200	270	MTY355M2-6	17.981 €	18.520 €	19.419 €
11	15	MTY160L-6	1.240 €	1.277 €	1.339 €	250	340	MTY355L-6	20.518 €	21.134 €	22.160 €
15	20	MTY180L-6	1.455 €	1.499 €	1.572 €						

\* Las potencias inferiores a 0,75kw no están contempladas en la normativa IEC\_60034-30 que regula las eficiencias de los motores

**MOTORES MONOFÁSICOS DE ALTO PAR ATX**
**MD (DISYUNTOR CENTRÍFUGO / ALTO PAR) 230V**

2 POLOS (3.000 RPM)						4 POLOS (1.500 RPM)					
kW	CV	Tipo	B3	B5/B14	B35/B34	kW	CV	Tipo	B3	B5/B14	B35/B34
						0,18	0,25	MD631-4	118 €	121 €	127 €
						0,25	0,33	MD631-4	129 €	133 €	139 €
0,37	0,5	MD711-2	142 €	146 €	153 €	0,37	0,5	MD712-4	138 €	142 €	149 €
0,55	0,75	MD712-2	145 €	149 €	156 €	0,55	0,75	MD801-4	176 €	181 €	190 €
0,75	1	MD801-2	168 €	173 €	181 €	0,75	1	MD802-4	188 €	193 €	203 €
1,1	1,5	MD802-2	198 €	204 €	214 €	1,1	1,5	MD90S-4	242 €	249 €	261 €
1,5	2	MD90S-2	237 €	244 €	256 €	1,5	2	MD90L-4	276 €	284 €	298 €
2,2	3	MD90L-2	268 €	276 €	289 €	2,2	3	MD100L1-4	372 €	383 €	402 €
3	4	MD100L-2	388 €	400 €	419 €	3	4	MD100L2-4	412 €	424 €	445 €

**MOTORES MONOFÁSICOS DE ALTO PAR ATX ALTA POTENCIA**
**MD (DISYUNTOR CENTRÍFUGO / ALTO PAR) 230V ALTA POTENCIA (CARCASA REDUCIDA)**

4 POLOS (1.500 RPM)					
kW	CV	Tipo	B3	B5/B14	B35/B34
2,2	3	MD90L2-4	390 €	402 €	421 €

**MOTORES MONOFÁSICOS ATX APLICACIÓN HORMIGONERAS**
**MD (DISYUNTOR CENTRÍFUGO / ALTO PAR) 230V. Con cable, switch (ON/OFF) y Polea a consultar**

4 POLOS (1.500 RPM)											
kW	CV	Tipo	B3	B5/B14	B35/B34	kW	CV	Tipo	B3	B5/B14	B35/B34
0,18	0,25	MD631-4	136 €	140 €	147 €	1,1	1,5	MD90S-4	268 €	276 €	289 €
0,25	0,33	MD631-4	147 €	151 €	159 €	1,5	2	MD90L-4	302 €	311 €	326 €
0,37	0,5	MD712-4	156 €	161 €	168 €	2,2	3	MD100L1-4	398 €	410 €	430 €
0,55	0,75	MD801-4	194 €	200 €	210 €	3	4	MD100L2-4	438 €	451 €	473 €
0,75	1	MD802-4	206 €	212 €	222 €						

**MOTORES TRIFÁSICOS ALTA POTENCIA (Carcasa reducida)**

2 POLOS (3.000 RPM)						4 POLOS (1.500 RPM)					
KW	CV	TIPO	B3	B5/B14	B35/B34	KW	CV	TIPO	B3	B5/B14	B35/B34
0,37	0,5	MT633-2	92 €	95 €	99 €	0,25	0,33	MT633-4	103 €	106 €	111 €
0,75	1	MT713-2	132 €	136 €	143 €	0,55	0,75	MT713-4	129 €	133 €	140 €
1,5	2	MT803-2	188 €	193 €	203 €	1,1	1,5	MT803-4	186 €	192 €	201 €
3	4	MT90L2-2	269 €	278 €	291 €	2,2	3	MT90L2-4	270 €	278 €	291 €
4	5,5	MT100L2-2	391 €	403 €	422 €	4	5,5	MT100L3-4	380 €	391 €	410 €
5,5	7,5	MT112L-2	456 €	470 €	492 €	5,5	7,5	MT112L-4	474 €	488 €	512 €
9,2	12,5	MT132M1-2	932 €	960 €	1.007 €	9,2	12,5	MT132L1-4	956 €	985 €	1.033 €
11	15	MT132M2-2	955 €	983 €	1.031 €	11	15	MT132L3-4	980 €	1.009 €	1.058 €

**AEG**
**MOTORES TRIFÁSICOS AEG IE3 (EFICIENCIA PREMIUM)**
**IE3**

2 POLOS (3.000 RPM) Fundición					4 POLOS (1.500 RPM) Fundición				
kW	CV	Ref.	Polos	PVP	kW	CV	Ref.	Polos	PVP
11	15	AMNH160SZA	2	1.286 €	11	15	AMNH160MAA	4	1.329 €
15	20	AMNH160MXA	2	1.432 €	15	20	AMNH160LAA	4	1.533 €
18.5	25	AMNH160LXA	2	1.552 €	18.5	25	AMNH180MZA	4	1.905 €
22	30	AMNH180MT	2	1.921 €	22	30	AMNH180LT	4	2.029 €
30	40	AMNH200LLA	2	2.572 €	30	40	AMNH200LNA	4	2.676 €
37	50	AMNH200LNA	2	2.847 €	37	50	AMNH225SN	4	3.305 €
45	60	AMNH225MN	2	3.739 €	45	60	AMNH225MG	4	3.695 €
55	75	AMNH250MN	2	4.673 €	55	75	AMNH250MN	4	4.572 €
75	100	AMNH280ST	2	5.675 €	75	100	AMNH280ST	4	5.655 €
90	125	AMNH280MT	2	6.510 €	90	125	AMNH280MT	4	6.413 €
110	150	AMNH315SYE	2	11.982 €	110	150	AMNH315SYE	4	10.456 €
132	180	AMNH315MZE	2	12.649 €	132	180	AMNH315MYE	4	11.711 €
160	200	AMNH315LRG	2	13.112 €	160	220	AMNH315MZE	4	13.680 €
200	270	AMNH315LG	2	14.428 €	200	270	AMNH315LZE	4	15.048 €
250	340	AMNH355M	2	25.854 €	250	340	AMNH355M4	4	24.929 €
315	430	AMNH355L	2	30.070 €	315	430	AMNH355LB	4	28.388 €



**ABB**
**MOTORES TRIFÁSICOS ABB IE3 (EFICIENCIA PREMIUM)**
**IE3**
**SERIE M2BA - Fundición**

2 POLOS (3.000 RPM)					4 POLOS (1.500 RPM)				
kW	CV	Tipo	B3	B5	kW	CV	Tipo	B3	B5
0.37	0,5	M2BAX 71 MC 2	210 €	249 €	0.25	0,33	M2BAX 71 MB 4	205 €	245 €
0.55	0,75	M2BAX 71 MB 1	237 €	276 €	0.37	0,5	M2BAX 71 MLA 4	230 €	270 €
0.75	1	M2BAX 80 MC 2	288 €	326 €	0.55	0,75	M2BAX 80 MC 4	255 €	297 €
1.1	1,5	M2BAX 80 MD 2	311 €	351 €	0.75	1	M2BAX 80 MLA 4	295 €	332 €
1.5	2	M2BAX 90 SB 2	369 €	413 €	1.1	1,5	M2BAX 90 SB 4	338 €	382 €
2.2	3	M2BAX 90 SLA 2	465 €	510 €	1.5	2	M2BAX 90 SLA 4	398 €	457 €
3	4	M2BAX 100 LKA 2	550 €	608 €	2.2	3	M2BAX 100 LB 4	486 €	562 €
4	5,5	M2BAX 112 MB 2	658 €	726 €	3	4	M2BAX 100 LKA 4	581 €	649 €
5.5	7,5	M2BAX 132 SMA 2	859 €	946 €	4	5,5	M2BAX 112 MLA 4	691 €	755 €
7,5	10	M2BAX 132 SME	1.067 €	1.150 €	5.5	7,5	M2BAX 132 SMA 4	885 €	965 €
11	15	M2BAX 160 MLA	1.562 €	1.696 €	7,5	10	M2BAX 132 SME	1.114 €	1.220 €
15	20	M2BAX 160 MLB	2.034 €	2.183 €	11	15	M2BAX 160 MLA	1.596 €	1.730 €
18,5	25	M2BAX 160 MLC	2.458 €	2.615 €	15	20	M2BAX 160 MLB	2.072 €	2.201 €
22	30	M2BAX 180 MLA	2.771 €	2.950 €	18,5	25	M2BAX 180 MLA	2.391 €	2.615 €
30	40	M2BAX 200 MLA	3.442 €	3.687 €	22	30	M2BAX 180 MLB	2.816 €	3.017 €
37	50	M2BAX 200 MLB	4.514 €	4.782 €	30	40	M2BAX 200 MLA	3.576 €	3.821 €
45	60	M2BAX 225 SMA	5.430 €	5.721 €	37	50	M2BAX 225 SMA	4.358 €	4.648 €
55	75	M2BAX 250 SMA	6.593 €	6.928 €	45	60	M2BAX 225 SMB	5.229 €	5.520 €
75	100	M2BAX 280 SMB	8.116 €	8.561 €	55	75	M2BAX 250 SMA	6.369 €	6.749 €
90	125	M2BAX 280 SMC	9.755 €	10.200 €	75	100	M2BAX 280 SMB	7.853 €	8.278 €
110	150	M2BAX 315 SMB	11.860 €	12.609 €	90	125	M2BAX 280 SMC	9.188 €	9.634 €
132	180	M2BAX 315 SMC	14.349 €	15.078 €	110	150	M2BAX 315 SMB	11.354 €	12.103 €
160	220	M2BAX 315 SMD	17.891 €	18.640 €	132	180	M2BAX 315 SMC	13.722 €	14.471 €
200	270	M2BAX 315 MLA	22.465 €	23.072 €	160	220	M2BAX 315 SMD	16.576 €	17.324 €
250	340	M2BAX 355 SMA	27.312 €	29.549 €	200	270	M2BAX 315 MLB	21.048 €	21.655 €
315	430	M2BAX 355 SMB	35.418 €	36.632 €	250	340	M2BAX 355 SMA	26.108 €	27.525 €
355	476	M2BAX 355 SMC	39.870 €	41.287 €	315	430	M2BAX 355 SMB	33.394 €	33.608 €
					355	476	M2BAX 355 SMC	37.644 €	38.858 €

**ABB**
**MOTORES TRIFÁSICOS ABB IE2 (ALTA EFICIENCIA)**
**IE2**
**SERIE M2AA - Aluminio**

2 POLOS (3.000 RPM)						4 POLOS (1.500 RPM)					
kW	CV	Tipo	B3	B5	B35	kW	CV	Tipo	B3	B5	B35
0,09	0,12	M2AA 56 A	145 €	161 €	222 €	0,06	0,08	M2AA 56 A	137 €	161 €	214 €
0,12	0,17	M2AA 56 B	145 €	161 €	222 €	0,09	0,12	M2AA 56 B	137 €	161 €	214 €
0,18	0,25	M2AA 63 A	147 €	163 €	224 €	0,12	0,17	M2AA 63 A	126 €	148 €	274 €
0,25	0,33	M2AA 63 B	148 €	166 €	225 €	0,18	0,25	M2AA 63 B	143 €	169 €	220 €
0,37 (1)	0,5	M2AA 71 A	153 €	180 €	230 €	0,25 *	0,33	M2AA 71 A	148 €	177 €	225 €
0,55 (1)	0,75	M2AA 71 B	171 €	200 €	248 €	0,37 * (1)	0,5	M2AA 71 B	168 €	197 €	245 €
0,75	1	M2AA 80 B	206 €	237 €	283 €	0,55 * (1)	0,75	M2AA 80 A	184 €	214 €	261 €
1,1	1,5	M2AA 80 C	226 €	255 €	303 €	0,75	1	M2AA 80 D	214 €	242 €	291 €
1,5	2	M2AA 90 L	269 €	300 €	372 €	1,1	1,5	M2AA 90 LB	245 €	277 €	338 €
2,2	3	M2AA 90 LB	338 €	371 €	441 €	1,5	2	M2AA 90 LD	288 €	332 €	391 €
3	4	M2AA 100 LB	400 €	441 €	503 €	2,2	3	M2AA 100 LC	353 €	393 €	456 €
4	5,5	M2AA 112 MB	478 €	527 €	581 €	3	4	M2AA 100 LD	422 €	470 €	525 €
5,5	7,5	M2AA 132 SB	623 €	686 €	726 €	4	5,5	M2AA 112 MB	499 €	548 €	602 €
7,5	10	M2AA 132 SC	775 €	836 €	878 €	5,5	7,5	M2AA 132 M	641 €	699 €	744 €
11	15	M2AA 160 MLA	1.186 €	1.287 €	1.388 €	7,5	10	M2AA 132 MA	809 €	883 €	912 €
15	20	M2AA 160 MLB	1.543 €	1.656 €	1.745 €	11	15	M2AA 160 MLA	1.211 €	1.312 €	1.413 €
18,5	25	M2AA 160 MLC	1.850 €	1.965 €	2.052 €	15	20	M2AA 160 MLB	1.572 €	1.671 €	1.774 €
22	30	M2AA 180 MLA	2.120 €	2.253 €	2.403 €	18,5	25	M2AA 180 MLA	1.786 €	1.929 €	2.069 €
30	40	M2AA 200 MLA	2.654 €	2.845 €	3.038 €	22	30	M2AA 180 MLB	2.139 €	2.292 €	2.422 €
37 (1)	50	M2AA 200 MLB	3.476 €	3.667 €	3.860 €	30	40	M2AA 200 MLA	2.769 €	2.960 €	3.153 €
45	60	M2AA 225 SMA	4.220 €	4.449 €	4.646 €	37	50	M2AA 225 SMA	3.342 €	3.571 €	3.726 €
55	75	M2AA 250 SMA	5.156 €	5.423 €	5.622 €	45	60	M2AA 225 SMB	4.068 €	4.297 €	4.494 €
						55	75	M2AA 250 SMA	4.946 €	5.213 €	5.412 €

# ABB

## MOTORES CON FRENO ABB

### SERIE M3VRS / M3VRF (CON FRENO-CORRIENTE ALTERNA)

2 POLOS (3.000 RPM) C.A.						4 POLOS (1.500 RPM) C.A.					
kW	CV	Tipo	B3	B5	B14	kW	CV	Tipo	B3	B5	B14
0,55	0,75	M3VRS 71 B			356 €	0,12	0,17	M3VRS 63A		294 €	294 €
0,75	1	M3VRS 80 A		412 €		0,18	0,25	M3VRS 63B		304 €	304 €
1,1	1,5	M3VRS 80 B	400 €	426 €		0,25	0,33	M3VRS 71 A		335 €	335 €
1,5	2	M3AR 90 S	529 €	568 €		0,37	0,5	M3VRS 71 B	315 €	339 €	339 €
2,2	3	M3AR 90 L	570 €	610 €		0,55	0,75	M3VRS 80 A	369 €	395 €	395 €
3	4	M3AR 100 L	735 €	785 €		0,75	1	M3VRS 80 B	383 €	409 €	409 €
4	5,5	M3AR 112 M	939 €	999 €		0,75	1	M3VRS 80 B		409 €	
5,5	7,5	M3AR 132 SA	1.262 €	1.340 €		1,1	1,5	M3AR 90 S	521 €	560 €	
7,5	10	M3AR 132 SB	1.410 €	1.489 €		1,5	2	M3AR 90 L	549 €	589 €	
						2,2	3	M3AR 100 LA	675 €	725 €	
						3	4	M3AR 100 LB	752 €	802 €	
						4	5,5	M3AR 112 M	915 €	975 €	
						5,5	7,5	M3AR 132 S	1.243 €	1.322 €	
						7,5	10	M3AR 132 M	1.387 €	1.466 €	

2 POLOS (3.000 RPM) Carcasa reducida. C.A.						4 POLOS (1.500 RPM) Carcasa reducida. C.A.					
kW	CV	Tipo	B3	B5	B14	kW	CV	Tipo	B3	B5	B14
2,7	3,6	M3AR 90 LF	658 €	698 €		0,25	0,33	M3VRS 63 BB		308 €	
4	5,5	M3AR 100LF	849 €	900 €		0,55	0,75	M3VRS 71 C		373 €	
5,5	7,5	M3AR 112MF	1.065 €	1.125 €		0,95	1,25	M3VRS 80 C		425 €	
9,2	12	M3AR 132 SF	1.640 €	1.719 €		1,85	2,5	M3AR 90 L	572 €	611 €	
11	15	M3AR 132SG	1.809 €	1.884 €		2,2	3	M3AR 90 LB	658 €	698 €	
						4	5,5	M3AR 100 LC	846 €	896 €	
						5,5	7,5	M3AR 112 MB	1.098 €	1.158 €	
						9,2	12	M3AR 132 MBA	1.612 €	1.691 €	
						11	15	M3AR 132 MB	2.278 €	2.353 €	

## MOTORES CON FRENO ATX

### SERIE MTF (CON FRENO-CORRIENTE CONTINUA)

2 POLOS (3.000 RPM)				4 POLOS (1.500 RPM)			
kW	CV	Tipo	PVP	kW	CV	Tipo	PVP
				0,18	0,25	MTFC632-4	266 €
				0,25	0,33	MTFC711-4	317 €
				0,37	0,5	MTFC712-4	331 €
				0,55	0,75	MTFC801-4	396 €
0,75	1	MTFC801-2	405 €	0,75	1	MTFC802-4	422 €
1,1	1,5	MTFC802-2	448 €	1,1	1,5	MTFC90S-4	491 €
1,5	2	MTFC90S-2	508 €	1,5	2	MTFC90L-4	517 €
2,2	3	MTFC90L-2	534 €	2,2	3	MTFC100L1-4	655 €
3	4	MTFC100L-2	724 €	3	4	MTFC100L2-4	724 €
4	5,5	MTFC112M-2	905 €	4	5,5	MTFC112M-4	897 €
5,5	7,5	MTFC132S1-2	1.216 €	5,5	7,5	MTFC132S-4	1.216 €
7,5	10	MTFC132S2-2	1.336 €	7,5	10	MTFC132M-4	1.380 €

FRENO ALIMENTADO A 400VAC Y A TRAVÉS DE RECTIFICADOR SE ALIMENTA LA BOBINA EN VDC

**REDUCTORES SINFIN CORONA - SERIE SM**

TIPO	EJE HUECO	P.A.M.	P.V.P.
<b>ALEACIÓN LIGERA</b>			
SM 25	11	TODAS	85 €
SM 30	14	TODAS	89 €
SM 40	18	TODAS	107 €
SM 50	25	TODAS	154 €
SM 63	25	TODAS	201 €
SM 75	28	TODAS	274 €
SM 90	35	TODAS	406 €
<b>FUNDICIÓN</b>			
SM 110	42	TODAS	605 €
SM 130	45	TODAS	828 €

**CARACTERÍSTICAS GENERALES**

- Carcasa en aluminio de alta calidad.
- Diseño robusto.
- Funcionamiento suave y silencioso.
- Elevada modularidad.
- Tamaños 25 a 185.
- Tamaño compacto y ligero.
- Gran fiabilidad y rendimiento.
- Alta capacidad de disipación.
- Amplia gama de accesorios.
- Par máximo de 2400 Nm.



<b>NUEVO DISEÑO</b>			
TIPO	EJE HUECO	P.A.M.	P.V.P.
<b>ALEACIÓN LIGERA</b>			
SM 25	11	TODAS	98 €
SM 30	14	TODAS	102 €
SM 40	18	TODAS	123 €
SM 50	25	TODAS	177 €
SM 63	25	TODAS	231 €
SM 75	28	TODAS	315 €
SM 90	35	TODAS	467 €

**ACCESORIOS**

TAMAÑO	BRIDA DE SALIDA				EJE DE SALIDA		BRAZO	TAPA	KIT COMB CON RETEN	
	FA	FB	FC	FD	DOBLE	SIMPLE	REACCIÓN	PLÁSTICO	TAMAÑO	PVP
25	8 €				11 €	10 €	11 €		30/40	18 €
30	9 €				15 €	13 €	11 €	1 €	30/50	18 €
40	10 €	15 €	15 €	12 €	17 €	14 €	13 €	1 €	30/63	19 €
50	13 €	17 €	21 €	20 €	21 €	20 €	16 €	2 €	40/75	19 €
63	16 €	18 €	31 €	33 €	24 €	22 €	20 €	2 €	40/90	20 €
75	25 €	27 €			29 €	27 €	26 €	3 €	50/90	21 €
90	34 €	47 €	36 €	37 €	43 €	32 €	31 €	3 €	50/110	21 €
110	49 €	83 €			47 €	34 €	43 €	7 €	63/130	27 €
130	65 €				57 €	39 €	56 €	9 €		



## ACCESORIOS

### BRIDA DE ENTRADA MOTOR (PAM)

TAMAÑO	56B14	56B5	63B14	63B5	71B14	71B5	80B14	80B5	90B14	90B5	100/112B14	100/112B5	132/B5
25													
30	10 €	10 €	10 €	10 €									
40		14 €	14 €	14 €	14 €	14 €							
50			23 €	23 €	23 €	23 €	23 €	23 €					
63					23 €	23 €	23 €	23 €	23 €				
75							32 €	32 €	32 €	32 €	32 €	32 €	
90							32 €	32 €	32 €	32 €	32 €	32 €	
110								75 €	75 €	75 €	75 €	75 €	75 €
130									94 €	94 €	94 €	94 €	94 €

### CASQUILLOS

REF.	DE INTERIOR A EXTERIOR	LONGITUD	PVP	REF.	DE INTERIOR A EXTERIOR	LONGITUD	PVP
C0911	9/11	22	9 €	C1924	19/24	50	17 €
C1114	11/14	28	11 €	C2428	24/28	60	19 €
C1419	14/19	40	14 €	C2838	28/38	70	29 €

## VARIADORES MECÁNICOS



kW	TIPO	PAM ENTRADA/SALIDA	P.V.P.
0,12 / 0,18	MV 63	11/140	294 €
0,25 / 0,37	MV 71	14/160	327 €
0,55 / 0,75	MV 80	19/200	390 €
1,1 / 1,5	MV 90	24/200	620 €
2,2 / 3 / 4	MV 112	28/250	1240 €

## PRERREDUCCIÓN



TIPO	RELACIÓN	PAM ENTRADA	PAM SALIDA	P.V.P.
P 63	3	11/140	11/105	165 €
P 71	3	14/160	14/120	197 €
P 80	3	19/200	19/160	280 €
P 90	2,42	24/200	24/160	287 €

## REDUCTORES PARA SISTEMAS ALIMENTACION GANADERA

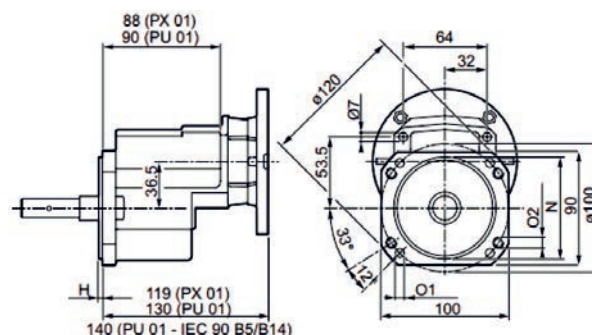

- Ejes macho de salida disponibles 16,19 y 21mm
- Pam de entrada 80

**MODULARIDAD ELEVADA**

- Reductores modulares con kit compactos para cambiar fácilmente la relación.

**VERSATILIDAD ELEVADA**

- 8 tamaños con 3 configuraciones de entrada.
- Amplia posibilidad de posiciones de montaje.
- Motor compacto integrado, para aplicaciones con espacios reducidos.

**FIABILIDAD ELEVADA**

- Carcasa robusta de hierro fundido adaptada para aplicaciones particularmente severas.
- Engranajes fabricados en acero de calidad de alta resistencia
- Rodamientos abundantemente dimensionados.
- Juntas de elevada calidad para asegurar una estanqueidad mayor.

**PRESTACIONES ELEVADAS**

- Potencia máxima aplicable 90Kw.
- Par máximo de transmisión 13840Nm.
- Relaciones de reducción de hasta 183/1.



Eficiencia: 94%-98%

Carcasa: HT250 Fundición de hierro

Engranajes: 20CrMnTi HRC58°~62 °

Ejes de e/s: 40Cr

Precisión: Grado 6

Aceite: Mineral ISO 220

Ruido: 65~70dB

Subida de temp. (MAX): 40 °C

Subida de temp(Aceite)(MAX): 50 °C

Vibración: 520µm

En stock en 3 tamaños (ejes huecos de 40, 50 y 60), con posibilidad de ejes reducidos (ejes huecos de 35, 45 y 55)

**INTERCAMBIABLE EN DIMENSIONES CON LA MAYOR PARTE DE LAS MARCAS CONTRASTADAS DEL MERCADO**
**DISPONIBLE EN TAMAÑOS DE HASTA 50.000NM Y EJE HUECO DE SALIDA DE Ø=190MM BAJO PEDIDO**
**Serie MEK**

TIPO 3 TRENES	POTENCIAS [kW]	EJE DE SALIDA Ø [mm]	PAM/IEC ENTRADA MOTOR	PAR SALIDA [Nm]	RELACIONES	PVP SIN ACEITE	PVP ACEITE *
MEK40	0,18-5,5 kW	40 mm Opcional 35 mm	63 - 132	810 Nm	7,28-144,80	1.467 €	45 €
MEK50	0,37-11 kW	50 mm Opcional 45 mm	71 - 160	1600 Nm	7,22-192,19	1.867 €	67 €
MEK60	0,75-22 kW	60 mm Opcional 55 mm	80 - 180	2800 Nm	7,21-197,38	2.467 €	90 €

\* La cantidad [litros] de aceite depende de la posición del montaje. Posición de montaje M1.

**REDUCTORES ORTOGONALES HIPOIDES Aleación ligera**

- **ALTO RENDIMIENTO: 90%-94%**
- **LARGA VIDA ÚTIL**
- **DISPONIBLE EN 4 TAMAÑOS**
- **POTENCIAS HASTA 4 KW**



## REDUCTORES EPICICLODALES ATX

### PL\PLB SERIES

- Reductores modulares con kit compactos para cambiar fácilmente la relación.
- Motor compacto integrado, para aplicaciones con espacios reducidos.
- Par de salida desde 500 Nm hasta 660000Nm.
- Potencia de hasta 110kw
- Los índices de reducción van desde 3:1 a 7:1 para los reductores con una sola etapa; hasta 10.000:1 para los reductores con 5 etapas de reducción.



## REDUCTORES COAXIALES ATX

### SERIE A/F DE 2 Y 3 TRENES DE ENGRANAJES

#### MODULARIDAD ELEVADA

- Reductores modulares con kit compactos para cambiar fácilmente la relación.
- Fijación con patas o mediante brida.

#### VERSATILIDAD ELEVADA

- 8 tamaños con 3 configuraciones de entrada.
- Amplia posibilidad de posiciones de montaje.
- Motor compacto integrado, para aplicaciones con espacios reducidos.

#### FIABILIDAD ELEVADA

- Carcasa robusta de hierro fundido adaptada para aplicaciones particularmente severas.
- Engranajes fabricados en acero de calidad de alta resistencia .
- Rodamientos abundantemente dimensionados.
- Juntas de elevada calidad para asegurar una estanqueidad mayor.

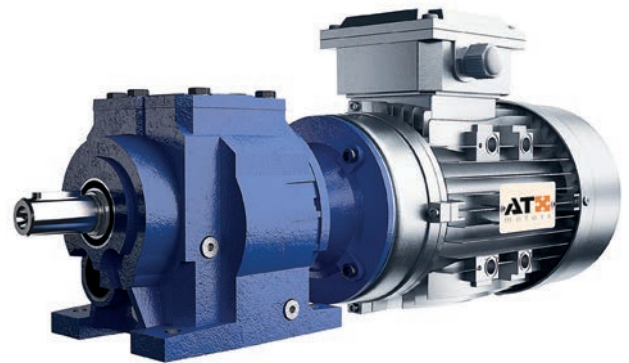

#### PRESTACIONES ELEVADAS

- Potencia máxima aplicable 45Kw.
- Par máximo de transmisión 9.600Nm.
- Relaciones de reducción de hasta 282/1.



## REDUCTORES PENDULARES ATX

### SERIE D/M DE 2 Y 3 TRENES DE ENGRANAJES

- Reductores modulares con kit compactos para cambiar fácilmente la relación.
- Motor compacto integrado, para aplicaciones con espacios reducidos.
- Par de salida desde 500 Nm hasta 660000Nm.
- Potencia de hasta 110kw
- Los índices de reducción van desde 3:1 a 7:1 para los reductores con una sola etapa; hasta 10.000:1 para los reductores con 5 etapas de reducción.



**\* CONSULTAR PRECIOS**

## TABLA DE DESCUENTOS

CLIENTE:

ARTÍCULOS	DESCUENTOS
MOTORES TRIFÁSICOS ATX	%
MOTORES MONOFÁSICOS ATX	%
MOTORES CON ELECTROFRENO ATX	%
MOTORES TRIFÁSICOS AEG	%
MOTORES TRIFÁSICOS, CON ELECTROFRENO ABB	%
REDUCTORES ORTOGONALES, COAXIALES Y PENDULARES ATX	%
REDUCTORES SIN FÍN CORONA Y ACCESORIOS ATX	%

Disponemos de **grandes descuentos** para nuestros clientes.

Para conocer tus descuentos, llámanos al **986872010**, envíanos un email a **egasen@egasen.com** o escanea el siguiente **código** con tu móvil y sigue el enlace para que te llamemos nosotros:

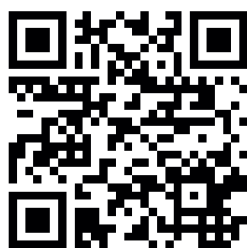

Recibir llamada

**DELTA**



Convertidores de frecuencia



Pantallas táctiles



Fuentes de alimentación



PLC



Terminales LCD Alfanuméricos



Servomotores y Servodrives



Contadores, Temporizadores y Tacómetros

**ABB**



Motores Trifásicos



Motores Freno



Arranadores suaves



Convertidores de frecuencia



Apararmenta industrial

**MAXGE**



Interruptores



Contactores



Guardamotores



Pulsatería industrial



Electro Gálvez y Senabre S.L.U.  
Polígono Industrial O Campiño, Parcela A 18  
36158 - Marcón  
Pontevedra - España  
Telf.: +34 986 872 010

@General: [egasen@egasen.com](mailto:egasen@egasen.com)

@Ventas y Presupuestos: [ventas@egasen.com](mailto:ventas@egasen.com)

[www.egasen.com](http://www.egasen.com)



DESCARGAR TARIFA